



# Prosumer-Haushalte

Private Haushalte als  
neue Schlüsselakteure einer  
Transformation des Energiesystems

## Modelling of Prosumer-households for Economic Evaluations

Presentation of the special approach for a prosumer-model

IAEE Bergen

Bergen, 22.06.2016

Dr. Swantje Gährs

Institute for Ecological Economy Research (IÖW)



# Modelling of Prosumer-households

---

## Goals for the modelling

- Simulation of different Prosumer-households
  - Differentiated according to technologies (production and consumption)
  - Differentiated according to consumption patterns
- Measuring effects on total end energy supply (i.e. due to Power-To-Heat)
- Mapping of the characteristic consumption and production patterns (load curve)
- Initial estimate on the physical load in the grid due to different types of Prosumers
- Using the results for economics evaluations



# The IÖW-Prosumer model: basic layout

- Mapping of production and consumption with a **time resolution of 1 min**
- Simulation of consumption **bottom-up** via measured and synthetic load profiles
- Simulation of production via **measured weather data** (Consideration of cloud course etc.)

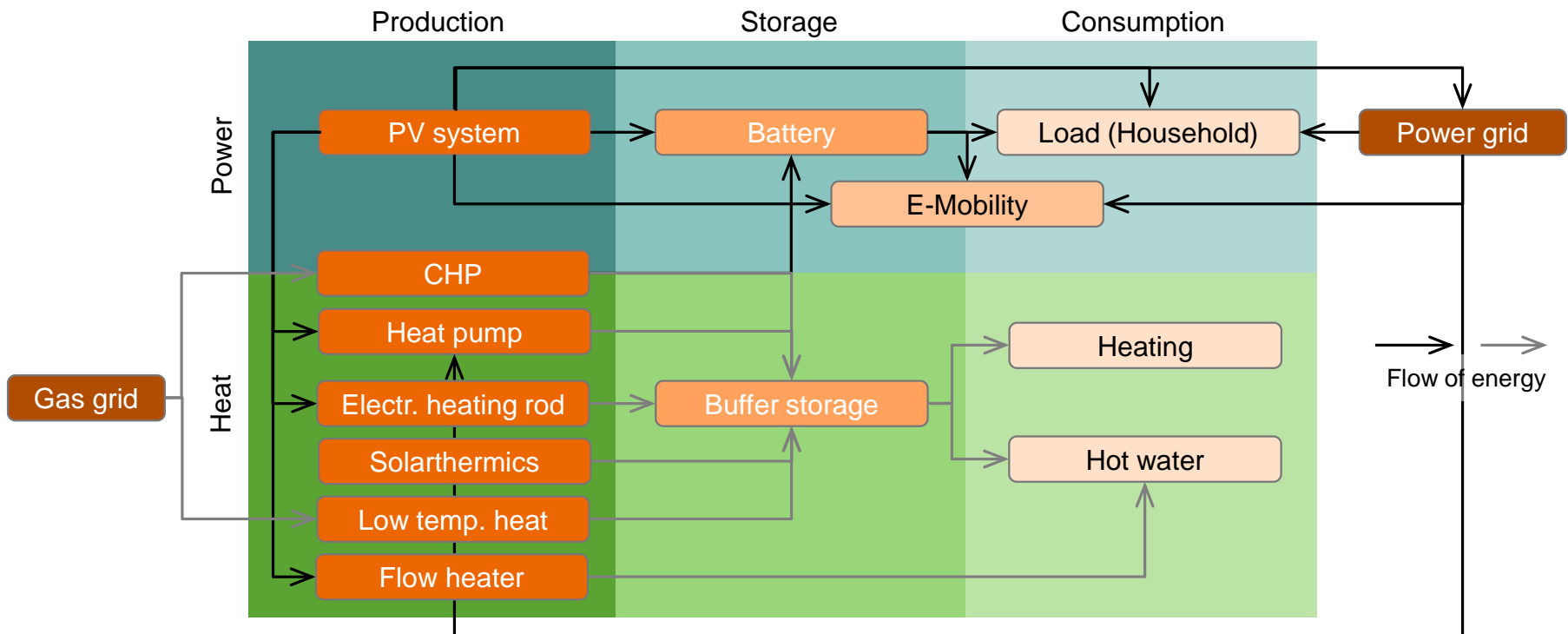



# Exemplary energy consumption on a exemplary day

What is happening?

Sleeping      Getting up      Leaving the house      Coming back home      Homework      Evening entertainment      Sleeping

The load curve

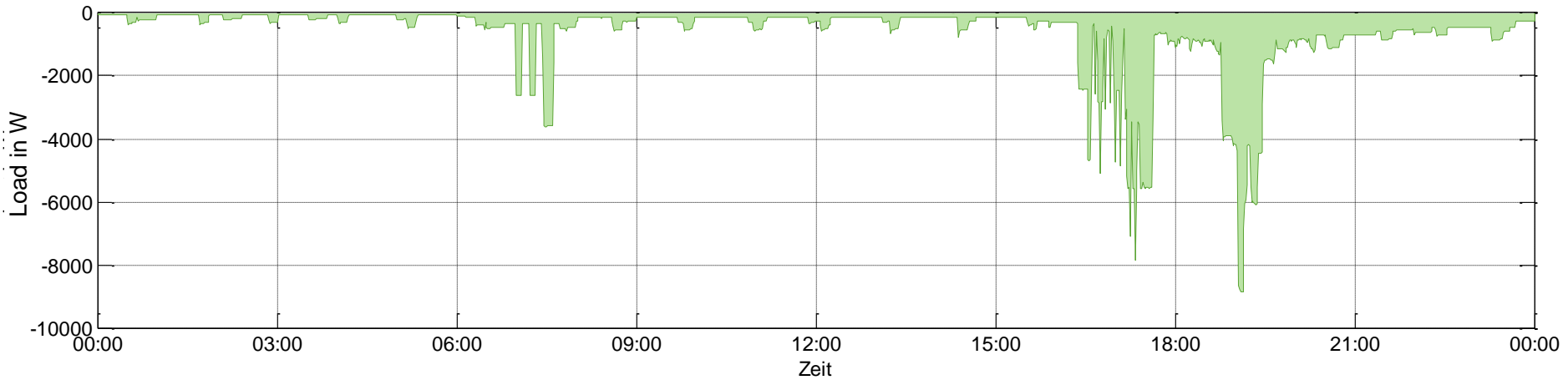

Who ist consuming energy?

Fridge  
Router  
Pump

Light

Kettle  
Toaster  
Coffee machine  
hair dryer

Light

Washing machine  
Dishwasher  
Vacuum cleaner

TV  
Computer  
Hifi



# Types of households and technologies

Types of households		Technologies	
Household size	1, 2, 3, 4, 5+	PV [s/ew] + load mgmt	
Building type	<ul style="list-style-type: none"> <li>• Old (partly renovated)</li> <li>• New (80/90s)</li> <li>• New (EnEV*)</li> </ul>	PV [s/ew] + Battery	
Energy efficiency	A/B/C/D/E/F/G following the “Stromspiegel” from BMUB**	PV [s/ew] + Heat pump + load mgmt	
		PV [s/ew] + electric heating + load mgmt	
		PV [s/ew] + CHP + load mgmt	
		CHP	
		CHP + Battery	

\* Energy Saving Regulations

\*\* Federal Ministry for the Environment, Nature Conservation, Building and Nuclear Safety



# Annual electricity balance: self consumption, grid purchase und feed-in

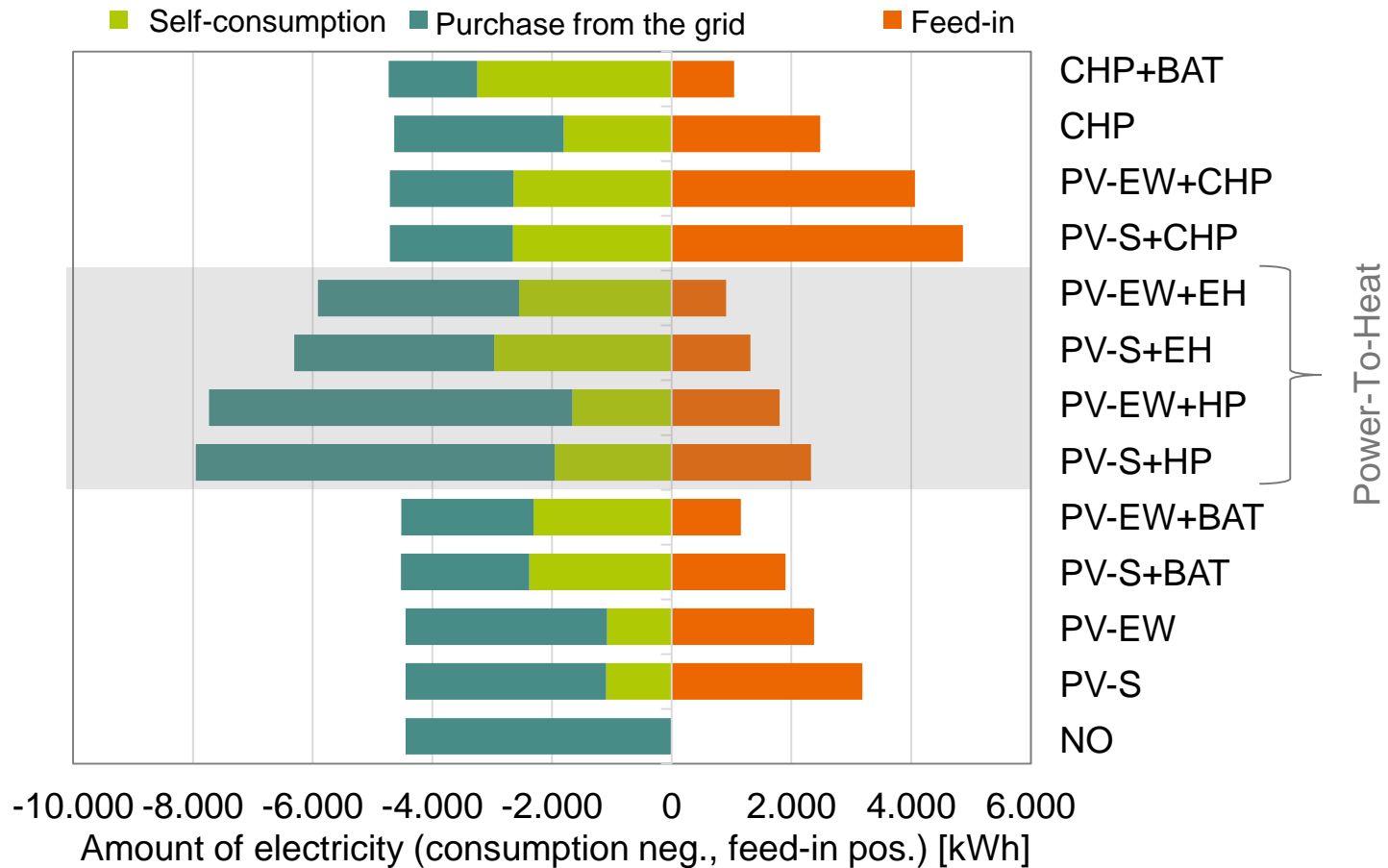



# Self-consumption and self-sufficiency rates for different types of prosumers

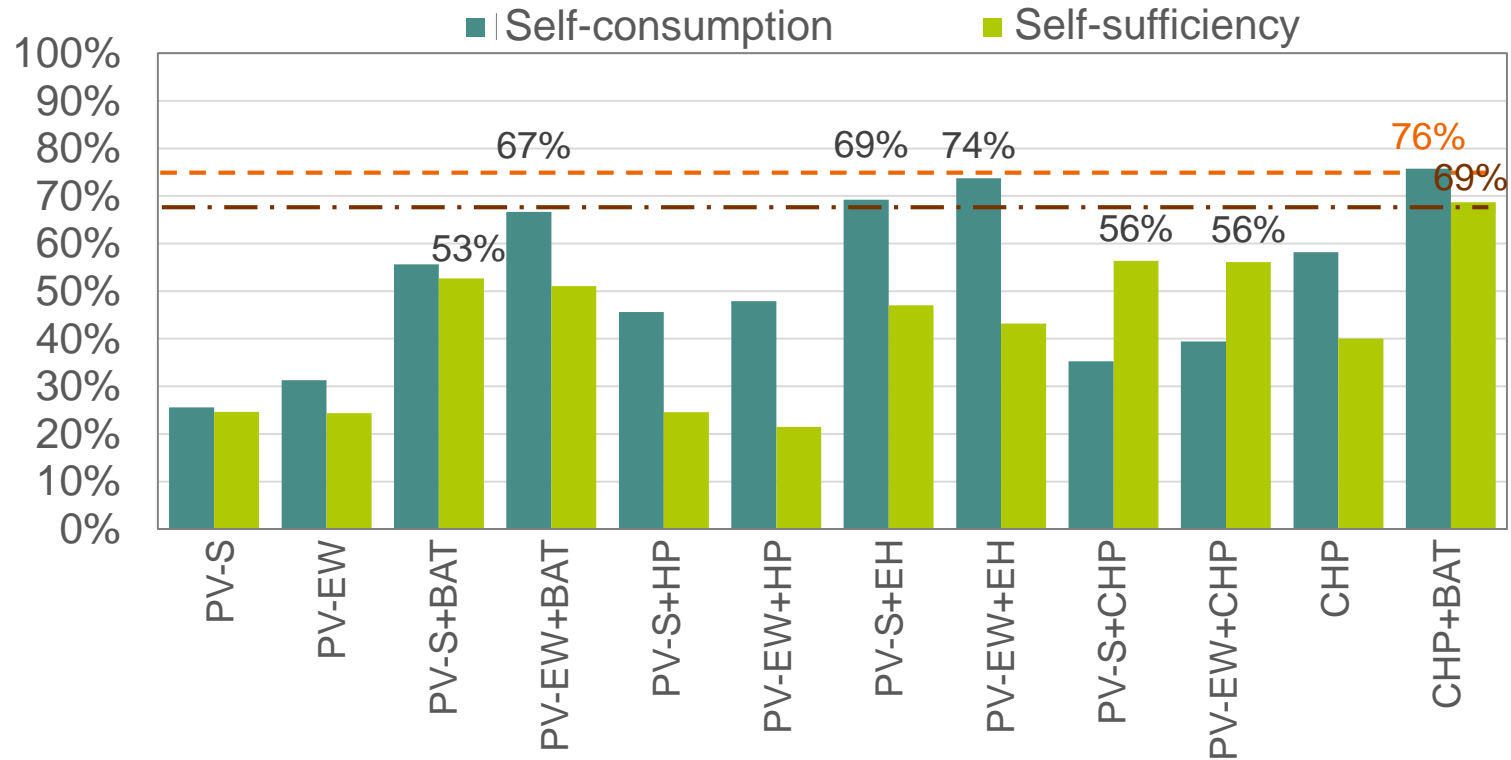



# Input parameters with influence on the energy consumption

- Number of persons in the household
- Energy efficiency
- Power-To-Heat
- E-mobility
- Presence time of the residents
- Options for load management

Impact on the amount of yearly energy consumption

Impact on the distribution of the load over time



# Options for load management

- Two options for load management have been implemented
  - Easy option with a timer (systematic optimization)
  - Optimized with an energy management system (smart optimization)

Load mgmt \ Appliances	systematic	smart
Washing machine/ Dish washer/ Dryer	Start with timer, independent of energy production	Optimized start depending on energy production
Fridge and Freezer	No energy consumed from 5-10 am	No energy consumed from 5-10 am
Small appliances	Mostly in the afternoon	Mostly in the afternoon



# Impact of the different load management options

## Energy input and feed-in for a 4-persons household

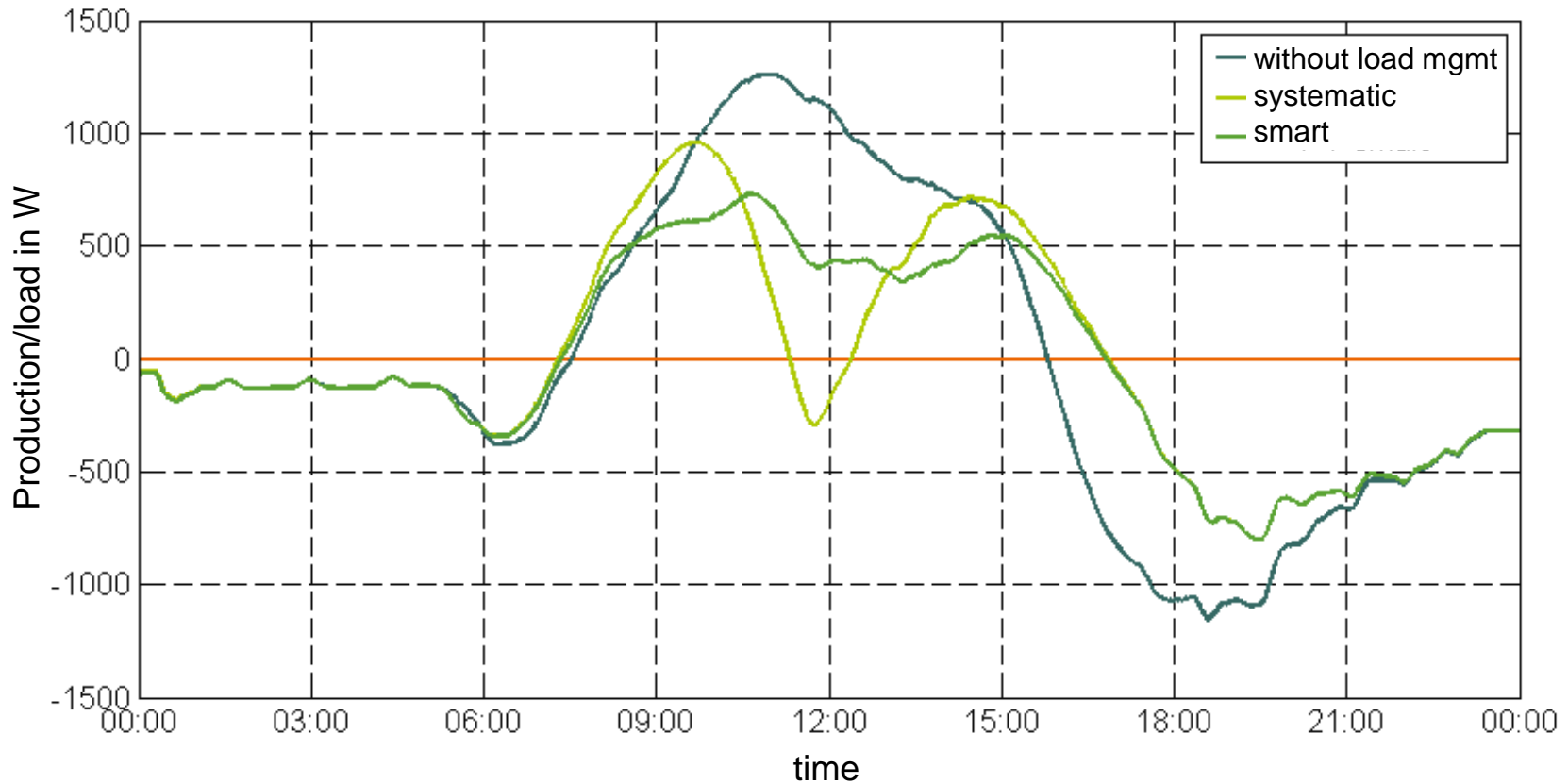



# Conclusions

---

- Prosumer-households are **very diverse** depending on
  - the installed technologies,
  - their dimensions,
  - the size of the household,
  - the consumption behavior and
  - the energy efficiency of electronical devices.
- All Parameters influence **self-consumption, self-sufficiency** and the **characteristically load curve**
- Self-consumption and self-sufficiency rates are together with energy prices and investment costs the **main economic parameters** and are **hard to predict**
- In conclusion the **economic and political frameworks** will influence which technology or which combination of technologies will be most attractive for Prosumer-households



# Prosumer-Haushalte

Private Haushalte als  
neue Schlüsselakteure einer  
Transformation des Energiesystems

Thank you for your attention.

IAEE Bergen  
Bergen, 22.06.2016

Dr. Swantje Gährs

Institute for Ecological Economy Research (IÖW)